

AFTERCARE INSTRUCTIONS

Your fitting has a high quality finish and should be treated with care to preserve the visible surfaces.

All surface finishes will wear if not cleaned correctly, the only safe way to clean your mixer is to wipe with a soft damp cloth. Stains can be removed using washing up liquid. All bath cleaning powders and liquids will damage the surface of your fitting, even the non-scratch cleaners. **NOTE: Never use abrasive detergents or disinfectants or those containing alcohol, hydrochloric acid or phosphoric acid.**

GUARANTEE

All products are manufactured to the highest standards and a 5 year guarantee covers any defect in manufacture.

NOTE: The 5-year guarantee on the cartridge is invalidated if damaged by any waterborne debris.

In the interests of continuous product development we reserve the right to alter specification as necessary

PRODUCT CODE:

PLEASE ENTER YOUR PRODUCT CODE ABOVE IN THE BOX PROVIDED, WHICH WILL BE REQUIRED FOR ANY FUTURE CORRESPONDENCE REGARDING THIS PRODUCT

PRODUCT IDENTIFICATION CODE LASER ETCHED ON PRODUCT
Installer please fill in code here _____ (Where applicable)

TELEPHONE HELPLINE! +44 (0)844 701 6273

Bristan Group Limited
Birch Coppice Business Park
Dordon
Tamworth
Staffordshire
B78 1SG
UK
A Masco Company
Website: www.bristan.com
Telephone: +44 (0) 844 701 6274
Facsimile: +44 (0) 844 701 6275
Email: enquire@bristan.com

(FI BIBGLO)

(Rev.D2)

BRISTAN

Bib or Globe Taps

Fitting Instructions & Contents List

Before starting any installation project please consider:

Prior to drilling into walls, check there are no hidden electrical wires, cables or water supply pipes with the aid of an electronic detector. If you use power tools do not forget:

- Wear eye protection
- Unplug equipment after use



Please keep these instructions for future reference and request of replacement part

WATER PRESSURE

This mixer is suitable for use at all supply pressures. However for optimum use both the hot and cold supplies should be reasonably balanced.

If the fitting is installed at low pressure (tank fed), then the minimum distance from the highest installed position of the shower head to the underside of the cold tank should be 1.8 metres to ensure adequate shower performance.

This mixer should be installed in compliance with the Water Regulations. Where the supplies are unbalanced, i.e. hot water from cylinder tank/cold from the mains, approved check valves must be fitted in the supply pipes. For further details contact your Local Water Authority.

INSTALLATION

1. Identify all components and check for completeness, particularly before arranging fitting.
2. Using a suitable thread sealant install the taps into the connectors (not provided) Globe taps are supplied with a threaded tube (1) and, if used this needs to be sealed into the tap body prior to connecting to pipework. The backnut (2) can be used to hold the Globe tap with the threaded tube in the wall.
3. Turn on the water supplies. Open both taps letting the water flow for a few Minutes to flush the system.
4. Check all joints and connections for leaks.
5. See over the page for aftercare instructions.

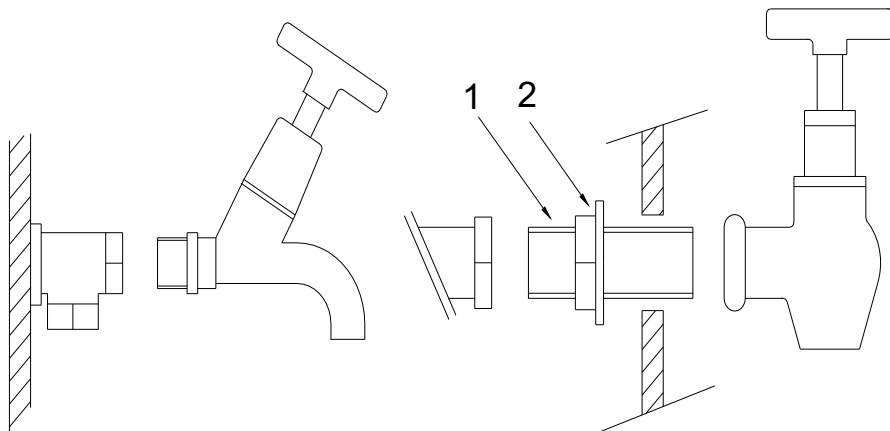

Before starting any installation project please consider:



Prior to drilling into walls, check there are no hidden electrical wires, cables or water supply pipes with the aid of an electronic detector. If you use power tools do not forget:

- Wear eye protection
- Unplug equipment after use

N.B. Please write the name and product code of your fitting in the spaces provided overleaf. This will ensure a speedier service if you should need to phone the help line.

MAINTENANCE

Sureflow type valves: - If the fitting self-opens

1. Remove fitting head.
2. Tighten gland nut on top of valve.

Traditional type valves: - If the fitting leaks from the spindle

1. Remove fitting head (if necessary).
2. Tighten gland nut on top of valve.

All valve types: - If the fitting begins to drip

1. Turn off the water supply.
2. Remove fitting head and valve.
3. Carefully clean seating and rubber washer.
4. Replace valve and turn on the water supply.
5. Contact our helpline if problem persists.

